

CMS03P06TL-HF

P-Channel
RoHS Device
Halogen Free

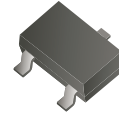

Features

- Low on resistance.
- Low gate charge.
- Fast switching characteristic.

Mechanical data

- Case: SOT-23-3L, molded plastic.
- Terminal: Solderable per MIL-STD-750, method 2026.
- Mounting position: Any.

Circuit Diagram

- G : Gate
- S : Source
- D : Drain

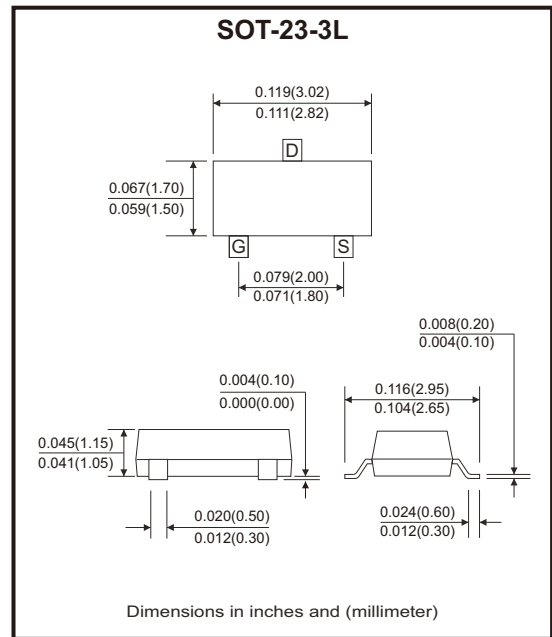
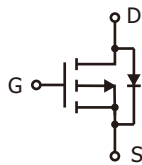

Maximum Ratings (at TA=25°C unless otherwise noted)

Parameter	Conditions	Symbol	Value	Unit
Drain-source voltage		V _{DS}	-60	V
Gate-source voltage		V _{GS}	±20	
Continuous drain current	V _{GS} = -10V, T _A = 25°C (Note 1)	I _D	-3.2	A
	V _{GS} = -10V, T _A = 70°C (Note 1)	I _D	-2.6	
Pulsed drain current	(Note 2)	I _{DM}	-13	A
Continuous body diode forward current	T _A = 25°C	I _S	-0.8	A
Pulsed body diode forward current	T _A = 25°C	I _{SM}	-3.2	A
Total power dissipation	T _A = 25°C (Note 1)	P _D	0.9	W
	T _A = 70°C (Note 1)	P _D	0.6	
Thermal resistance junction-ambient	(Note 1)	R _{θJA}	137	°C/W
Operating junction and storage temperature range		T _J , T _{STG}	-55 to +150	°C

Notes: 1. The value of R_{θJA} is measured with the device mounted on 1 in² FR-4 board with 2oz. copper, in a still air environment with T_A=25°C. The power dissipation P_D is based on R_{θJA} and the maximum allowed junction temperature of 150°C. The value in any given application depends on the user's specific board design.

2. Repetitive rating, pulse width limited by junction temperature T_{J(MAX)}=150°C. Ratings are based on low frequency and low duty cycles to keep initial T_J=25°C.

Electrical Characteristics (at $T_A=25^\circ\text{C}$ unless otherwise noted)

Parameter	Symbol	Conditions	Min	Typ	Max	Unit
Static						
Drain-source breakdown voltage	BV_{DSS}	$V_{GS} = 0V, I_D = -250\mu A$	-60			V
Gate threshold voltage	$V_{GS(th)}$	$V_{DS} = V_{GS}, I_D = -250\mu A$	-1		-2.5	V
Forward transconductance	g_{fs}	$V_{DS} = -15V, I_D = -3A$		5.5		S
Gate-source leakage current	I_{GSS}	$V_{GS} = \pm 20V, V_{DS} = 0V$			± 100	nA
Drain-source leakage current	I_{DSS}	$V_{DS} = -48V, V_{GS} = 0V$			-1	μA
Static drain-source on-resistance	$R_{DS(on)}$	$V_{GS} = -10V, I_D = -2A$		80	104	m Ω
	$R_{DS(on)}$	$V_{GS} = -4.5V, I_D = -1A$		109	150	m Ω
Dynamic						
Input capacitance	C_{iss}	$V_{DS} = -30V, V_{GS} = 0V, f = 1MHz$		500		pF
Output capacitance	C_{oss}			51		
Reverse transfer capacitance	C_{rss}			37		
Gate resistance	R_g	$f = 1MHz$		6.6		Ω
Total gate charge (Note 1,2)	Q_g	$V_{DS} = -30V, I_D = -3A, V_{GS} = -4.5V$		6.1		nC
Total gate charge (Note 1,2)	Q_g	$V_{DS} = -30V, I_D = -3A, V_{GS} = -10V$		11		
Gate-source charge (Note 1,2)	Q_{gs}			2		
Gate-drain charge (Note 1,2)	Q_{gd}			3.2		
Turn-on delay time (Note 1,2)	$t_{d(on)}$	$V_{DS} = -30V, I_D = -3A, V_{GS} = -10V$ $R_{GS} = 3\Omega$		6.4		nS
Rise time (Note 1,2)	t_r			17		
Turn-off delay time (Note 1,2)	$t_{d(off)}$			25		
Fall time (Note 1,2)	t_f			7.2		
Source-drain diode						
Diode forward voltage (Note 1)	V_{SD}	$I_S = -3A, V_{GS} = 0V$		-0.84	-1.2	V
Reverse recovery time	t_{rr}	$I_F = -3A, dI_F/dt = 100A/\mu s, V_R = 30V$		13		nS
Reverse recovery charge	Q_{rr}				8	

Notes: 1. Pulse width $\leq 300\mu s$, duty cycle $\leq 2\%$.
2. Independent of operating temperature.

Typical Rating and Characteristic Curves (CMS03P06TL-HF)

Fig.1 - Typical Output Characteristics

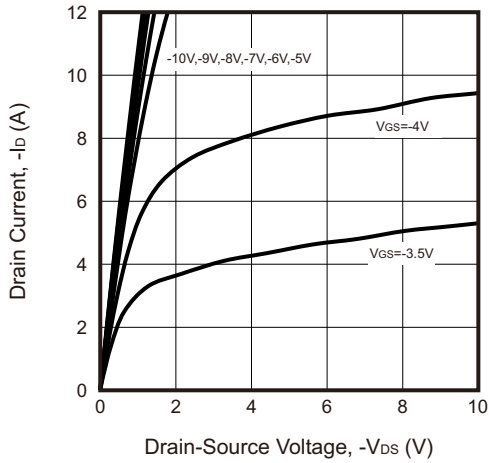

Fig.2 - Breakdown Voltage vs Ambient Temperature

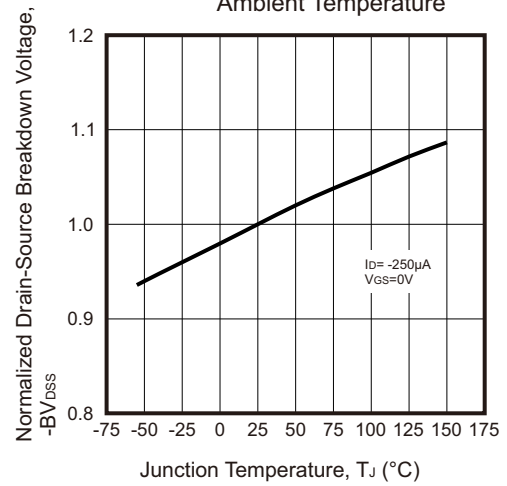

Fig.3 - Static Drain-Source On-State Resistance vs Drain Current

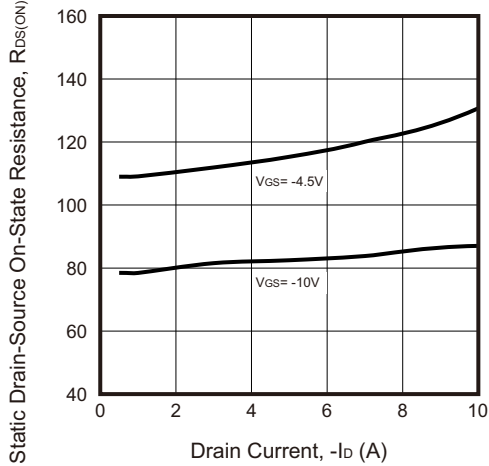

Fig.4 - Body Diode Current vs Source-Drain Voltage

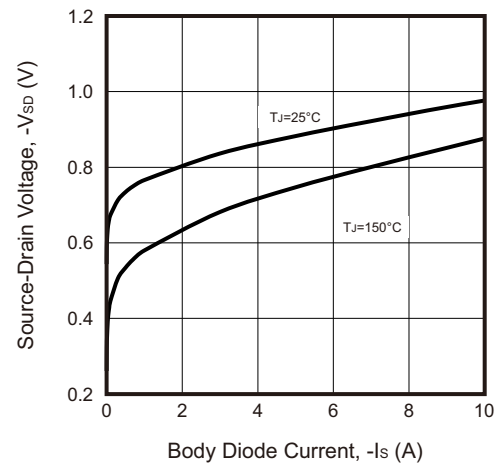

Fig.5 - Static Drain-Source On-State Resistance vs Gate-Source Voltage

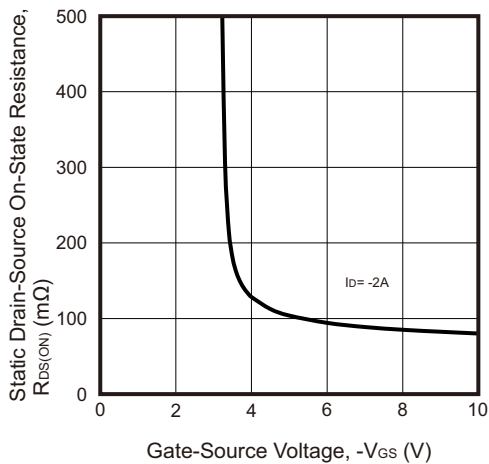
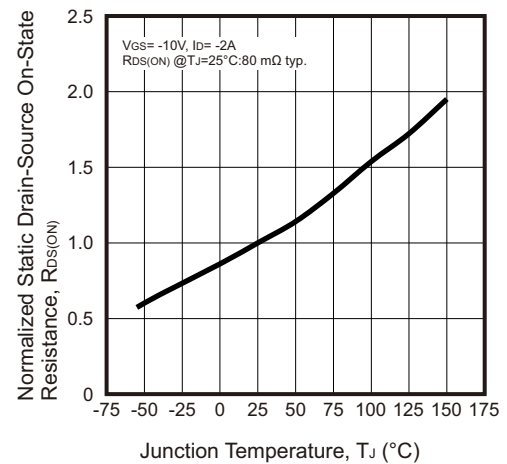

Fig.6 - Drain-Source On-State Resistance vs Junction Temperature



Typical Rating and Characteristic Curves (CMS03P06TL-HF)

Fig.7 - Capacitance vs Drain-to-Source Voltage

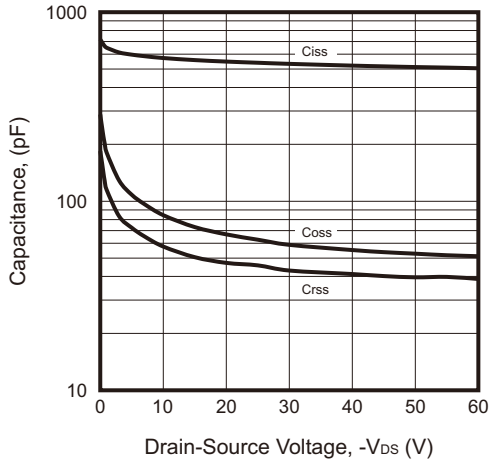

Fig.8 - Threshold Voltage vs Junction Temperature

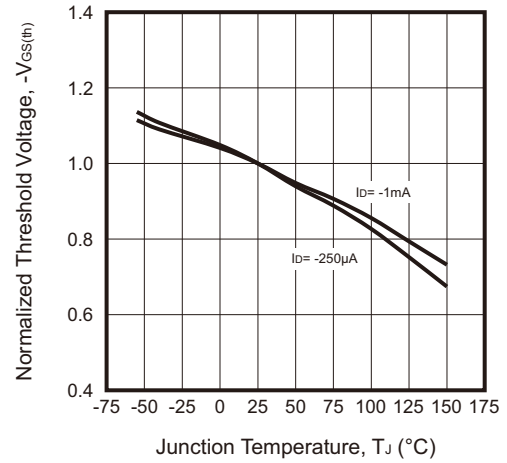

Fig.9 - Forward Transfer Admittance vs Drain Current

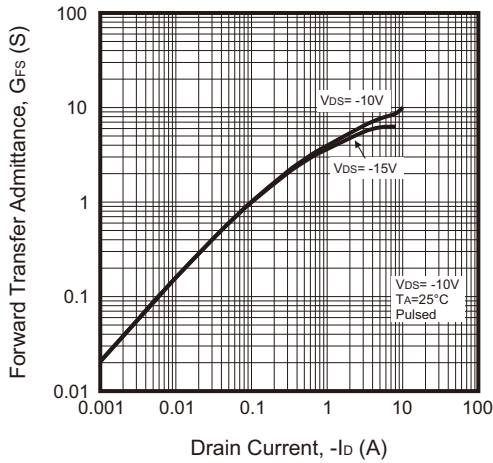

Fig.10 - Gate Charge Characteristics

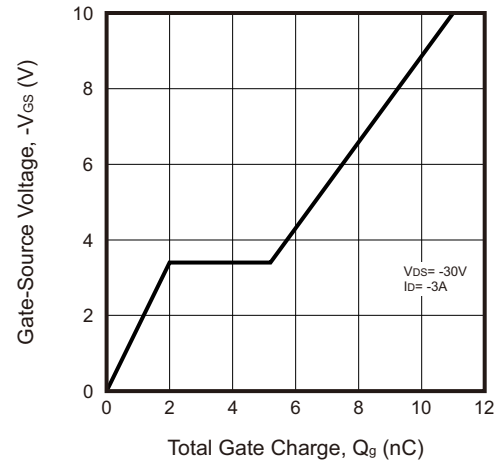

Fig.11 - Maximum Safe Operating Area

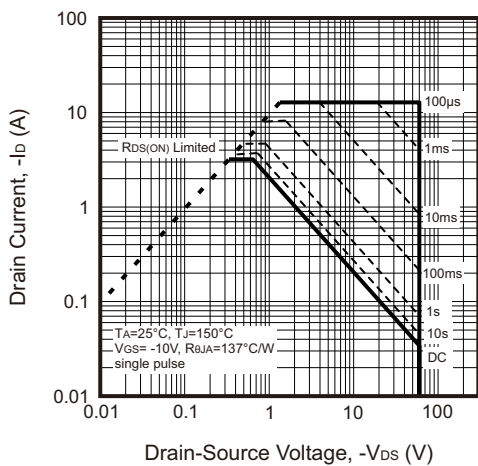
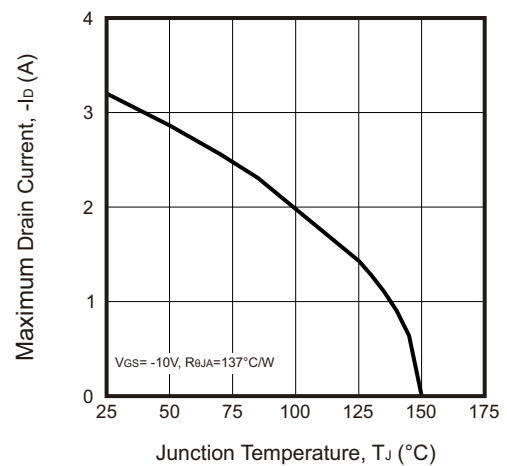
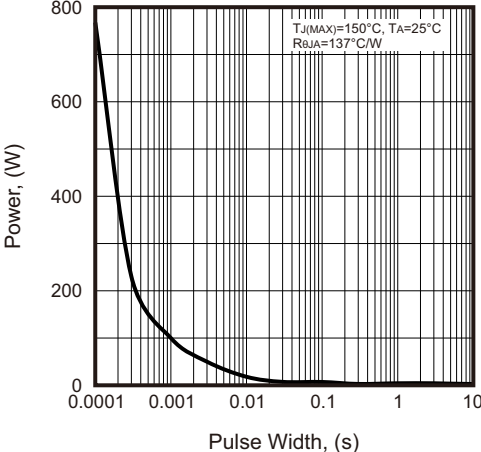

Fig.12 - Maximum Drain Current vs Junction Temperature



Typical Rating and Characteristic Curves (CMS03P06TL-HF)

Fig.13 - Single Pulse Power Rating,
Junction to Ambient



Reel Taping Specification

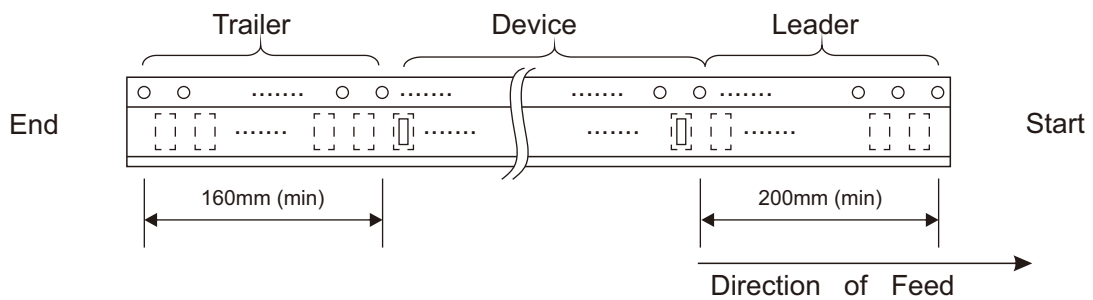
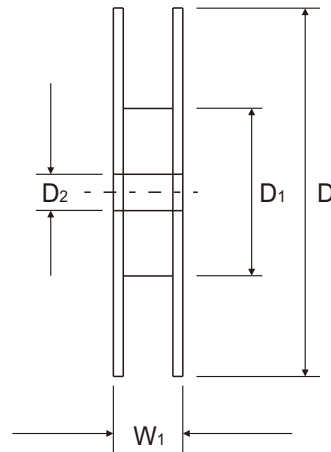
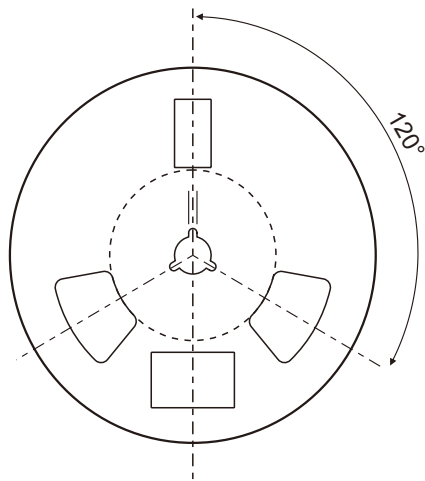
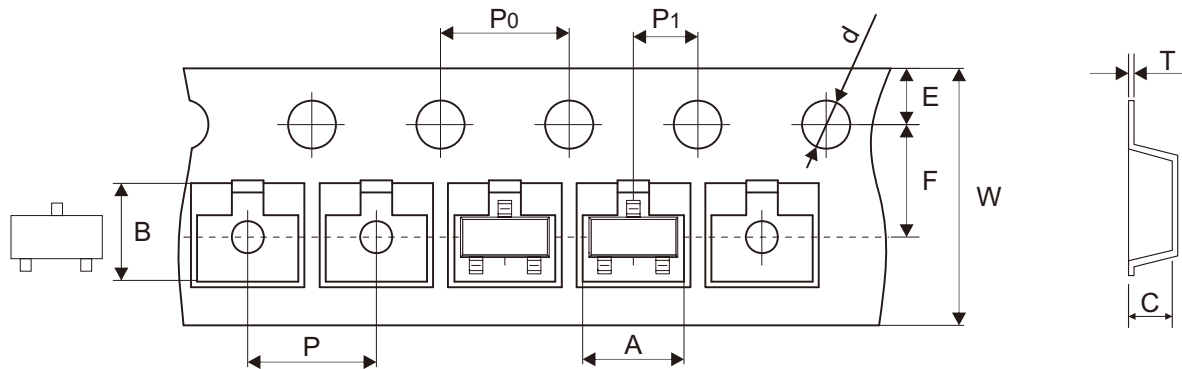

SOT-23-3L	SYMBOL	A	B	C	d	D	D ₁	D ₂
	(mm)	3.17 ± 0.15	3.23 ± 0.12	1.37 ± 0.10	1.50 + 0.10 - 0.00	178.00 ± 1.00	55.00 ± 1.00	13.00 + 0.50 - 0.20
	(inch)	0.125 ± 0.006	0.127 ± 0.005	0.054 ± 0.004	0.059 + 0.004 - 0.000	7.008 ± 0.039	2.165 ± 0.039	0.512 + 0.020 - 0.008

SOT-23-3L	SYMBOL	E	F	P	P ₀	P ₁	T	W	W ₁
	(mm)	1.75 ± 0.10	3.50 ± 0.05	4.00 ± 0.10	4.00 ± 0.10	2.00 ± 0.05	0.22 ± 0.02	8.00 + 0.30 - 0.10	12.00 ± 0.50
	(inch)	0.069 ± 0.004	0.138 ± 0.002	0.157 ± 0.004	0.157 ± 0.004	0.079 ± 0.002	0.009 ± 0.001	0.315 + 0.012 - 0.004	0.472 ± 0.020

Marking Code

Part Number	Marking Code
CMS03P06TL-HF	B8P6

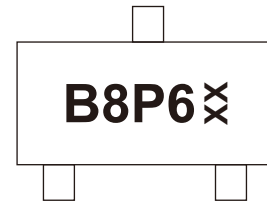

XX = Control code

Suggested P.C.B. PAD Layout

SIZE	SOT-23-3L	
	(mm)	(inch)
A	1.00	0.039
B	0.80	0.031
C	1.90	0.075
D	2.02	0.080
E	1.20	0.047
F	0.30	0.012

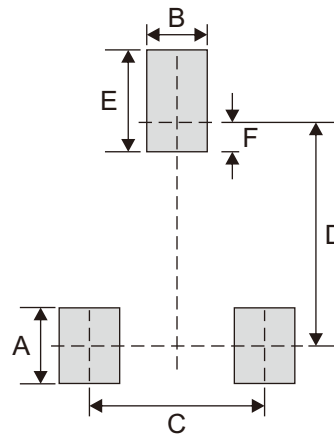

Standard Packaging

Case Type	REEL PACK	
	REEL (pcs)	Reel Size (inch)
SOT-23-3L	3,000	7